

Floodlight LED

Series 6525/2

Contents

1	General Information	3
1.1	Manufacturer	3
1.2	Information regarding the operating instructions	3
1.3	Further documents	3
1.4	Conformity with standards and regulations	3
2	Explanation of the symbols	4
2.1	Symbols in these operating instructions	4
2.2	Warning notes	4
2.3	Symbols on the device	5
3	Safety notes	5
3.1	Operating instructions storage	5
3.2	Safe use	5
3.3	Intended Use	6
3.4	Modifications and alterations	6
4	Function and device design	6
4.1	Function	6
4.2	Device design	7
5	Technical data	8
6	Transport and storage	14
7	Mounting and installation	15
7.1	Dimensions / fastening dimensions	16
7.2	Mounting / dismounting, operating position	17
7.3	Installation	19
8	Commissioning	23
9	Maintenance, Overhaul, Repair	24
9.1	Maintenance	24
9.2	Repair	26
9.3	Returning the device	27
10	Cleaning	27
11	Disposal	27
12	Accessories and Spare parts	28

1 General Information

1.1 Manufacturer

R. STAHL Schaltgeräte GmbH
Am Bahnhof 30
74638 Waldenburg
Germany

Phone: +49 7942 943-0
Fax: +49 7942 943-4333
Internet: r-stahl.com
E-mail: info@r-stahl.com

R. STAHL (P) LTD., Plot No. - 5
Malrosapuram Road, Sengundram Indl. Area
Singaperumal Koil, Kancheepuram Dist.,
Tamil Nadu – 603 204, INDIA

Phone: +91 44-67 300 600
Fax: +91 44-67 300 700
Internet: r-stahl.com/en/in
E-mail: sales@rstahl.net

R. STAHL Schaltgeräte GmbH
Business Unit Lighting & Signalling
Nordstr. 10
99427 Weimar
Germany

Phone: +49 3643 4324
Fax: +49 3643 4221-76
Internet: r-stahl.com
E-mail: info@r-stahl.com

1.2 Information regarding the operating instructions

ID-No.: 282892 / 652560300080
Publication Code: 2021-03-25-BA00-III-en-02

The original instructions are the English edition.
They are legally binding in all legal affairs.

1.3 Further documents

- Data sheet
- For documents in additional languages, see r-stahl.com.

1.4 Conformity with standards and regulations

See certificates and EU Declaration of Conformity: r-stahl.com.
The device has IECEx approval. For certificate please refer to the IECEx homepage:
<http://iecex.iec.ch/>
Further national certificates can be downloaded via the following link:
<https://r-stahl.com/en/global/support/downloads/>.

2 Explanation of the symbols

2.1 Symbols in these operating instructions

Symbol	Meaning
	Tips and recommendations on the use of the device
	Danger due to explosive atmosphere
	Danger due to live components
	Risk of damage to the eyes caused by optical radiation



2.2 Warning notes

Warnings must be observed under all circumstances, in order to minimize the risk due to construction and operation. The warning notes have the following structure:

- Signalling word: DANGER, WARNING, CAUTION, NOTICE
- Type and source of danger/damage
- Consequences of danger
- Taking countermeasures to avoid the danger or damage

	DANGER
	Danger to persons Non-compliance with the instruction results in severe or fatal injuries to persons.
	WARNING
	Danger to persons Non-compliance with the instruction can result in severe or fatal injuries to persons.
	CAUTION
	Danger to persons Non-compliance with the instruction can result in light injuries to persons.
NOTICE	
Avoiding material damage Non-compliance with the instruction can result in material damage to the device and / or its environment.	

2.3 Symbols on the device

Symbol	Meaning
 0158 <small>0594E00</small>	CE marking according to the currently applicable directive.
 <small>02198E00</small>	According to marking, device approved for hazardous areas.

3 Safety notes

3.1 Operating instructions storage

- Read the operating instructions carefully.
- Store the operating instructions at the mounting location of the device.
- Observe applicable documents and operating instructions of the devices to be connected.

3.2 Safe use

Before mounting

- Read and observe the safety notes in these operating instructions!
- Ensure that the contents of these operating instructions are fully understood by the personnel in charge.
- Use the device in accordance with its intended and approved purpose only.
- Always consult R. STAHL Schaltgeräte GmbH if using the device under operating conditions which are not covered by the technical data.
- We cannot be held liable for damage to the device caused by incorrect or unauthorised use or non-compliance with these operating instructions.

For assembly and installation

- Observe national assembly and installation regulations (e.g. IEC/EN 60079-14).
- Observe national safety and accident prevention regulations.
- During installation and operation, observe the information (characteristic values and rated operating conditions) on the type plates and data plates and information signs located on the device.
- Before installation, make sure that the device is not damaged.

Maintenance, repair, commissioning



- Before commissioning, make sure that the device is not damaged.
- Work on the device, such as installation, maintenance, overhaul, repair, may only be carried out by appropriately authorised and trained personnel.
- Perform only maintenance work or repair described in these operating instructions.

3.3 Intended Use

The LED floodlight 6525/2 is equipment

- for lighting areas, work spaces and objects
- can be used indoors and outdoors
- for stationary mounting
- for use in Zones 21, 2, 22 and in the safe area

3.4 Modifications and alterations

	DANGER
	<p>Explosion hazard due to modifications and alterations to the device! Non-compliance results in severe or fatal injuries.</p> <ul style="list-style-type: none"> • Do not modify or alter the device.
	No liability or warranty for damage resulting from modifications and alterations.

4 Function and device design

	DANGER
	<p>Explosion hazard due to improper use! Non-compliance results in severe or fatal injuries.</p> <ul style="list-style-type: none"> • Use the device only in accordance with the operating conditions described in these operating instructions. • Use the device only for the intended purpose specified in these operating instructions.

4.1 Function

Application range

The LED floodlight 6525/2 is equipment used for lighting areas, work equipment and objects.

It can be used indoors and outdoors.

The floodlight is certified for use in Zones 2, 21 and 22 hazardous areas.

4.2 Device design

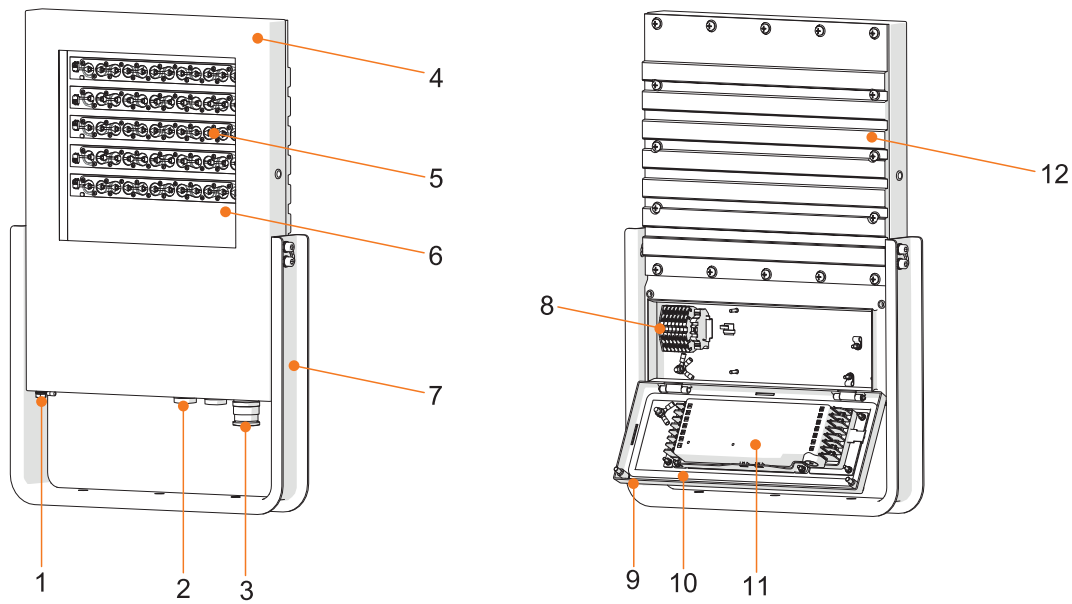

22206E00

- | | | | |
|---|------------------------|----|----------------------------|
| 1 | External PE connection | 7 | Mounting bracket |
| 2 | Stopping plug | 8 | Connection terminal |
| 3 | Cable entry | 9 | Cover connection enclosure |
| 4 | Enclosure | 10 | Seal connection enclosure |
| 5 | LED | 11 | Control gear |
| 6 | Luminaire glass cover | 12 | Heat sink |

5 Technical data

Explosion Protection

Global (IECEX)

Gas and dust

IECEX EPS 15.0032
 Ex nR IIC T6 ... T4 Gc (Type 6525/21..)
 Ex db ec IIC T4 Gc (Type 6525/22..)
 Ex tb op is IIIC T80 °C ... T100 °C Db

Europe (ATEX)

Gas and dust

EPS 15 ATEX 1 991
 Ⓢ II 3 G Ex nR IIC T6...T4 Gc (Type 6525/21..)
 Ⓢ II 3 G Ex db ec IIC T4 Gc (Type 6525/22..)
 Ⓢ II 2 D Ex tb op is IIIC T80 °C ... T100 °C Db

	Variant	Driver	Ambient temperature	Temperature class	Max. surface temperature
6525/21..-17..-.....-	100 W	Standard	≤ +60 °C	T6 ¹⁾ / T5	+ 80 °C
6525/21..-17..-.....-	100 W	Standard	≤ +50 °C	T6	+ 80 °C
6525/2...-15..-.....- 6525/2...-16..-.....-	100 W	6040	≤ +60 °C	T4	+ 100 °C
6525/21..-15..-.....- 6525/21..-16..-.....-	100 W	6040	≤ +50 °C	T6	+ 80 °C
6525/21..-35..-.....- 6525/21..-36..-.....- 6525/21..-37..-.....-	160 W	6040 Standard	≤ +60 °C	T5	+ 100 °C
6525/22..-35..-.....- 6525/22..-36..-.....-	160 W	6040	≤ +60 °C	T4	+ 100 °C
6525/21..-57..-.....-	225 W	Standard	≤ +60 °C	T5	+ 100 °C
6525/2...-55..-.....- 6525/2...-56..-.....-	225 W	6040	≤ +60 °C	T4	+ 100 °C

¹⁾ When the through wiring $I_N \leq 10$ A and the luminaire is not mounted facing upwards (in the position of the control gear)

Certifications and certificates

Certificates

IECEX, ATEX

Technical Data

Electrical data

Control gear

Rated voltage

6525/21..:
AC: 110 to 277 V ±10%; 50 to 60 Hz
DC: 127 to 250 V

6525/22..:
without DALI
AC: 110 to 277 V ±10%; 50 to 60 Hz
DC: 175 to 275 V

with DALI
AC: 100 to 277 V ±10%; 50 to 60 Hz
DC: 99 to 275 V

Rated current

	Variant 100 W	Variant 160 W	Variant 225 W
110 V AC	≤ 1.05 A	≤ 1.61 A	≤ 2.38 A
230 V AC	≤ 0.50 A	≤ 0.74 A	≤ 1.10 A
277 V AC	≤ 0.42 A	≤ 0.63 A	≤ 0.91 A

Inrush current

6525/21..:

Variant	Voltage	Inrush current		light fittings per circuit breaker							
		I _{peak}	Δt	B10	B16	B20	B25	C10	C16	C20	C25
100 W, 160 W	110 V AC	32 A	560 μs	3	5	6	7	3	5	9	9
	230 V AC	57 A	500 μs	2	4	5	6	4	7	9	11
	277 V AC	75.5 A	550 μs	1	2	3	4	2	4	7	7
225 W	110 V AC	36 A	500 μs	2	4	5	6	3	4	7	7
	230 V AC	64 A	500 μs	2	3	4	6	4	6	8	10
	277 V AC	78.5 A	550 μs	1	3	3	4	3	5	8	8

6525/22..:

Variant	Voltage	Inrush current		light fittings per circuit breaker							
		I _{peak}	Δt	B10	B16	B20	B25	C10	C16	C20	C25
100 W	110 V AC	0 A	> 100 μs	6	10	13	16	7	11	14	17
	230 V AC	0 A	> 100 μs	15	24	30	37	16	25	31	38
	277 V AC	0 A	> 100 μs	19	31	39	49	20	32	40	50
160 W	110 V AC	0 A	> 100 μs	4	7	8	11	5	8	9	12
	230 V AC	0 A	> 100 μs	10	16	20	25	11	17	21	26
	277 V AC	0 A	> 100 μs	13	21	26	32	14	22	27	33
225 W	110 V AC	0 A	> 100 μs	3	5	6	8	4	6	7	9
	230 V AC	0 A	> 100 μs	7	11	14	17	8	12	15	18
	277 V AC	0 A	> 100 μs	9	15	18	23	10	16	19	24

Technical Data

Power factor	> 0.95
THD	≤ 13%
Surge Protection	6525/21.. (nR version): N - PE: 10 kV L - PE: 10 kV L - N: 6 kV 6525/22.. (ec version): N - PE: 4 kV L - PE: 4 kV L - N: 2 kV
Protection class	I (with internal PE connection)

Luminous characteristics

Standard
 Light colour: Neutral white
 Colour temperature [K]: 5,000 K
 Colour rendering R_a : ≥80
 Application example: lighting of desktops

	6525/2...-1...- ...5-...	6525/2...-3...- ...5-...	6525/2...-5...- ...5-...
Variant	100 W	160 W	225 W
Power consumption [W]	100	155	220
Wide-beam			
Luminous flux [lm]	10,824	15,550	20,909
Luminaire efficacy [lm/W]	108	100	95
Medium-beam			
Luminous flux [lm]	10,701	15,413	20,909
Luminaire efficacy [lm/W]	107	99	95
Narrow-beam			
Luminous flux [lm]	11,088	15,822	21,490
Luminaire efficacy [lm/W]	111	102	98

Technical Data

Alternative

Light colour: Warm white
 Colour temperature [K]: 4,000 K
 Colour rendering R_a : ≥ 80
 Application example: lighting of desktops

	6525/2...-1...- ...4-...	6525/2...-3...- ...4-...	6525/2...-5...- ...4-...
Variant	100 W	160 W	225 W
Power consumption [W]	100	155	220

Wide-beam

Luminous flux [lm]	10,455	15,020	20,196
Luminaire efficacy [lm/W]	102	94	92

Medium-beam

Luminous flux [lm]	10,336	14,888	20,196
Luminaire efficacy [lm/W]	103	96	92

Narrow-beam

Luminous flux [lm]	10,710	15,283	20,757
Luminaire efficacy [lm/W]	107	99	94

Light colour: Cool white
 Colour temperature [K]: 5,700 K
 Colour rendering R_a : ≥ 70
 Application example: Lighting outside areas

	6525/2...-1...- ...1-...	6525/2...-3...- ...1-...	6525/2...-5...- ...1-...
Variant	100 W	160 W	225 W
Power consumption [W]	100	155	220

Wide-beam

Luminous flux [lm]	12,315	17,640	23,723
Luminaire efficacy [lm/W]	123	114	108

Medium-beam

Luminous flux [lm]	12,160	17,444	23,806
Luminaire efficacy [lm/W]	122	113	108

Narrow-beam

Luminous flux [lm]	12,565	18,022	24,562
Luminaire efficacy [lm/W]	126	116	111

Values apply to $T_a = +25\text{ }^\circ\text{C}$.

Technical Data

Luminous flux decline

• during DC operation to 50% (only type 6525/22..)
6525/21..-

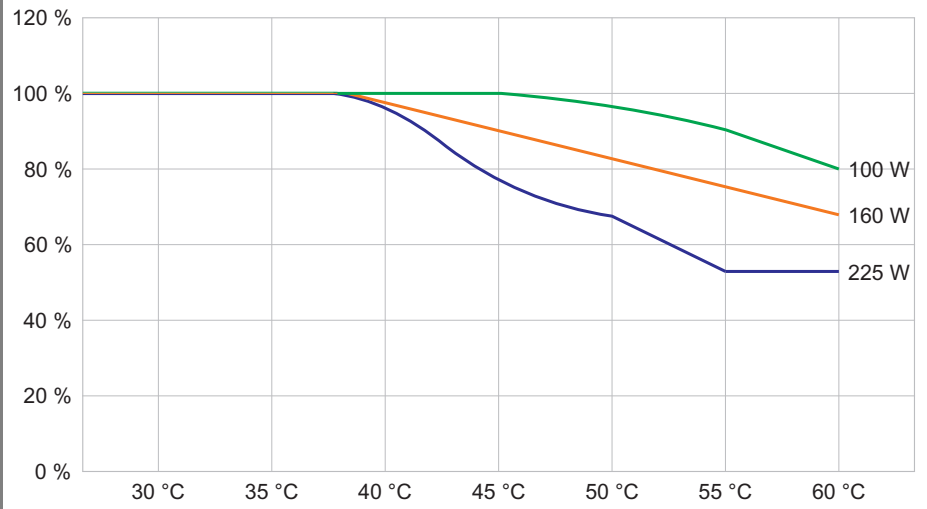

6525/22..-

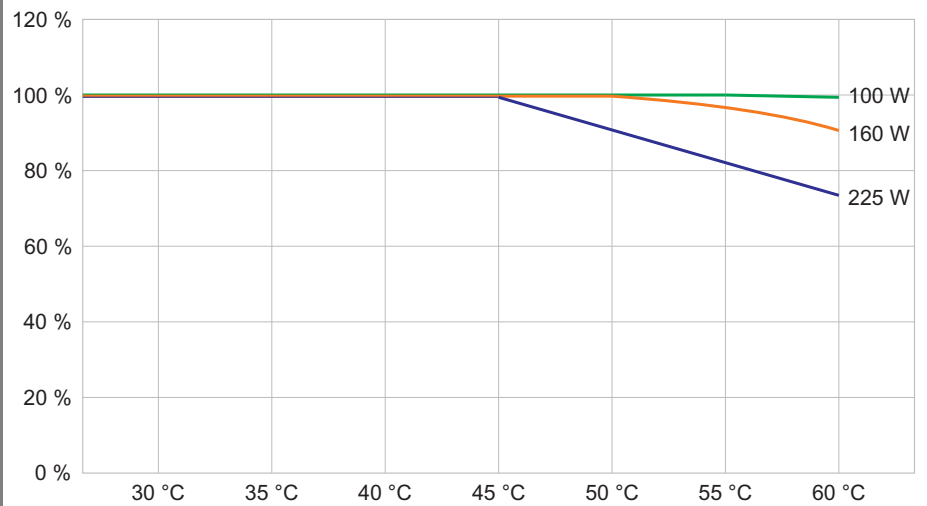

22195E00

Technical Data

Ambient conditions

Operating temperature range	Variant 100 W: -50* to +60 °C Variant 160 W: -60* to +60 °C Variant 225 W: -60* to +60 °C
Storage temperature	-40 to +75 °C

* Note: Possible to operate the luminaire below -40 °C, provided the luminaire is switched on at -40 °C. Delay of 10 seconds below -40 °C.

Service life

LED	L ₉₀ B ₅₀ : 66,000 h at T _a max.								
LED control gear	<p>L_xB_y At the end of the service life:</p> <ul style="list-style-type: none"> • Luminous flux declines to "x" percent • Up to "y" percent of all luminaires fall below "x" <table border="1" style="width: 100%; border-collapse: collapse;"> <thead> <tr> <th style="width: 50%;"></th> <th style="text-align: center;">C10</th> </tr> </thead> <tbody> <tr> <td>T_a ≤ +25 °C</td> <td style="text-align: center;">100,000 h</td> </tr> <tr> <td>+25 °C ≤ T_a ≤ +40 °C</td> <td style="text-align: center;">60,000 h</td> </tr> <tr> <td>+40 °C ≤ T_a ≤ +60 °C</td> <td style="text-align: center;">50,000 h</td> </tr> </tbody> </table>		C10	T _a ≤ +25 °C	100,000 h	+25 °C ≤ T _a ≤ +40 °C	60,000 h	+40 °C ≤ T _a ≤ +60 °C	50,000 h
	C10								
T _a ≤ +25 °C	100,000 h								
+25 °C ≤ T _a ≤ +40 °C	60,000 h								
+40 °C ≤ T _a ≤ +60 °C	50,000 h								

Mechanical data

Degree of protection	IP66
Impact strength (IK code)	IK10 (IEC 62262)
Material	
Enclosure, cover and bracket	<p>6525/.....-.....-331 Stainless steel SS304 (1.4301 or V2A), Enclosure, cover with single powder coating, bracket without powder coating</p> <p>6525/.....-.....-242 Stainless steel SS316L (1.4404 or V4A), Enclosure, cover with double powder coating (offshore coating), bracket without powder coating</p>
Enclosure colours	Colour white, similar to RAL 9010
Seal (cover)	Foamed silicone in luminaire cover
Luminaire glass cover	Toughened glass
Luminaire locking	Cheese-head screws TORX M6

Technical Data

Mounting / Installation

Cable entry

6525/21...:

1 x cable gland Series CMP A2F
 1 x cable gland Series 8161 with red stopping plug
 (Test opening for the restricted breathing test)
 1 x stopping plug Series 8290

6525/22...:

1 x cable gland Series CMP A2F
 2 x stopping plugs Series 8290

Connection

Spring clamp terminals
 Standard: 5-pole: L1, L2, L3, N, PE
 with DALI: 7-pole: L1, L2, L3, N, PE, D1, D2
 Clamping range:
 1x 1.5 to 6 mm² (solid)
 1x 1.5 to 4 mm² (finely stranded)
 1x 1.5 to 6 mm² (finely stranded with core end sleeves)
 (2 free clamping units per pole available)

Loop in/loop out wiring

max. 16 A

Optional

DALI-connection



DALI-interface in accordance with IEC 62386-207:2009-08
 The maximum permissible voltage drop on the DALI conductor is defined with a maximum of 2 V.
 This corresponds with a maximum conductor length of 300 m, with a conductor cross-section of 1.5 mm².

For further technical data, see r-stahl.com.

6 Transport and storage

- Transport and store the device only in the original packaging.
- Store the device in a dry place (no condensation) and vibration-free.
- Do not drop the device.

7 Mounting and installation

	<p style="text-align: center;">DANGER</p> <p>Explosion hazard due to electrostatic discharge! Non-compliance results in severe or fatal injuries.</p> <p>Do not use the device in strong charge generating environments!</p> <p>The following processes/activities should be avoided:</p> <ul style="list-style-type: none"> • accidental friction • particle currents
	<p style="text-align: center;">DANGER</p> <p>Explosion hazard due to incorrect installation of the device! Non-compliance results in severe or fatal injuries.</p> <ul style="list-style-type: none"> • Carry out installation strictly according to the instructions and national safety and accident prevention regulations to maintain the explosion protection. • Select and install the electrical device so that explosion protection is not affected due to external influences, i.e. pressure conditions, chemical, mechanical, thermal and electric impact such as vibration, humidity and corrosion (see IEC/EN 60079-14). • The device must only be installed by trained qualified personnel who is familiar with the relevant standards.
<p style="text-align: center;">NOTICE</p> <p>Malfunction or device damage caused by condensation. Non-compliance can result in material damage!</p> <ul style="list-style-type: none"> • operate the luminaire continuously or periodically over extended periods of time. • avoid thermal bridges. 	

7.1 Dimensions / fastening dimensions

Dimensional drawings (all dimensions in mm [inches]) – Subject to modification

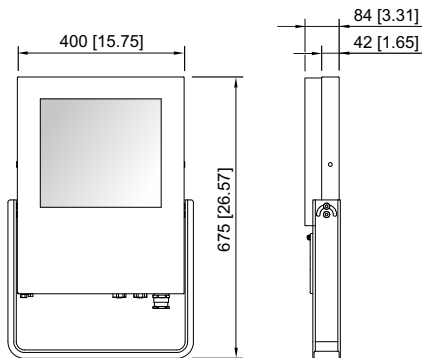

22203E00

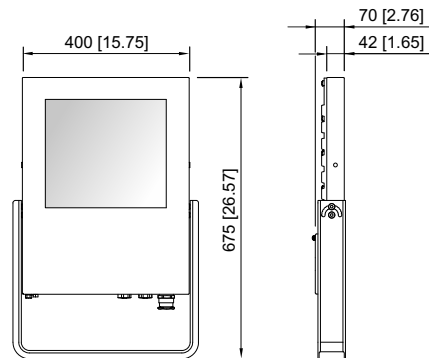

22204E00

Floodlights

Heat sink with fins
 (6525/21...: Variant 225 W,
 6525/22...: Variant 160 W,
 Variant 225 W)

Floodlights

Heat sink without fins
 (6525/21...: Variant 100 W,
 Variant 160 W,
 6525/22...: Variant 100 W)

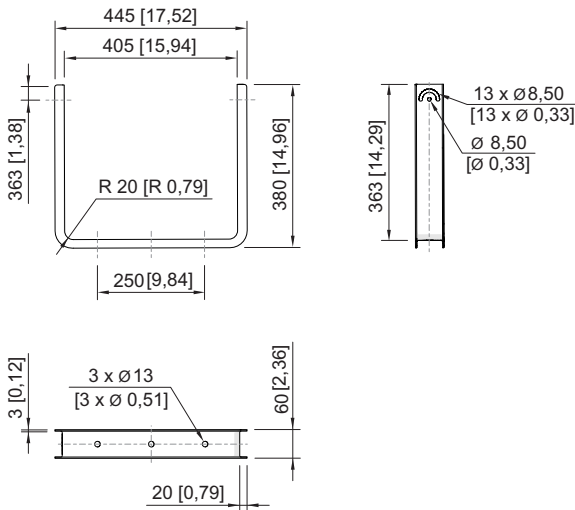

17561E00

Mounting bracket

Dimensional drawings (all dimensions in mm [inches]) – Subject to modification

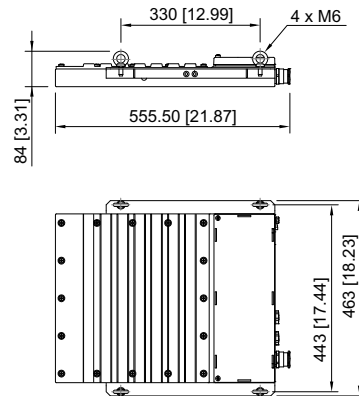
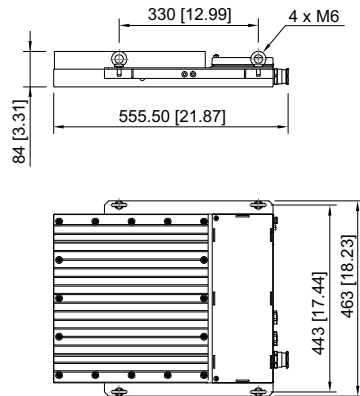



22209E00

22208E00

Floodlights with ring eyes
Heat sink with fins
(6525/21...: Variant 225 W
6525/22...: Variant 160 W,
Variant 225 W)

Floodlights with ring eyes
Heat sink without fins
(6525/21...: Variant 100 W,
Variant 160 W
6525/22...: Variant 100 W)

7.2 Mounting / dismounting, operating position

	DANGER
	<p>Explosion hazard due to inadmissible heating! Non-compliance results in severe or fatal injuries.</p> <ul style="list-style-type: none"> • Avoid external heat sources and/or direct sunlight (risk of change of temperature class or change of maximum permissible surface temperature). • Do not exceed the maximum ambient temperature due to external heat sources (premature failure of equipment).
	CAUTION
	<p>Risk of damage to the eyes caused by optical radiation! Non-compliance can result in light injuries!</p> <ul style="list-style-type: none"> • A minimum distance of 7.751 m between the luminaire and the eye of the viewer must be maintained for the version with narrow-beam light distribution.
	<p>The luminaire is suitable for wall, ceiling mounting and pole mounting with a mounting bracket. Do not install the luminaire so that light is emitted upward and/or so that the cable entry is pointing upward.</p>

- Maximum tightening torque of 10 Nm for connection screw of the mounting bracket and floodlight.
- Pendant mounting with ring eyes (M6).

Mounting alignment

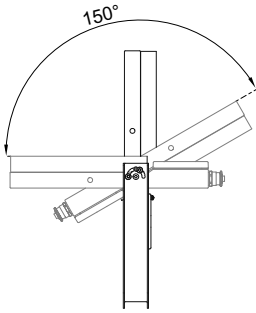

22244E00

Pole mounting

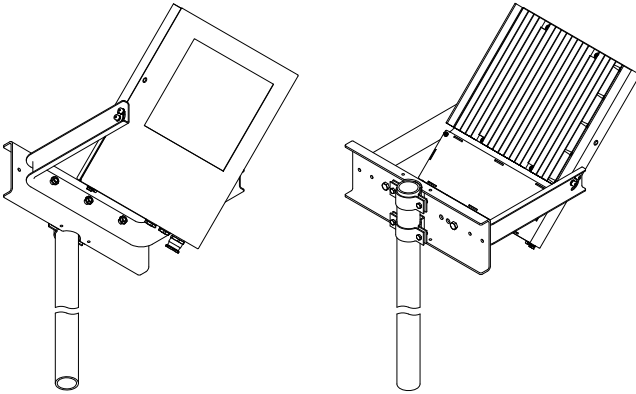

22243E00

Mounting with fall protection

i	The floodlight can be further protected in unexpected situations by mounting 2 ring eyes (1).
----------	---

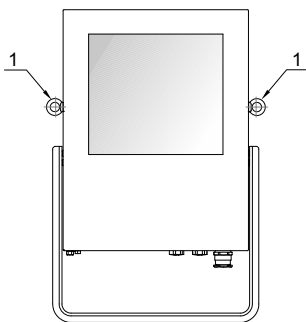

22242E00

7.3 Installation

7.3.1 Opening and Closing of the Enclosure

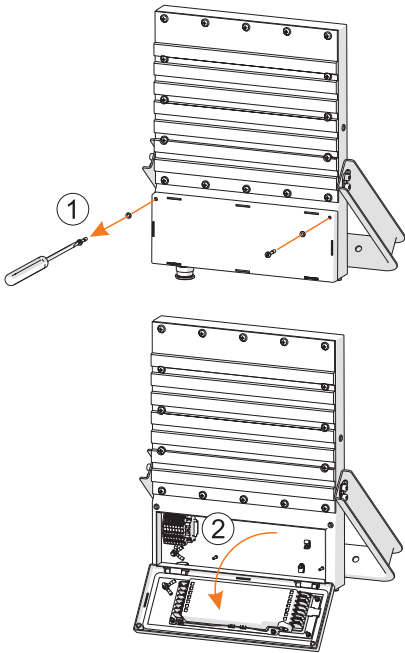
	DANGER
	<p>Risk of electric shock due to improper opening! Non-compliance results in severe or fatal injuries.</p> <ul style="list-style-type: none"> • Only open luminaires in a de-energised state.
NOTICE	
<p>Danger due to electrostatic discharge. Electronic components can be destroyed if touched.</p> <ul style="list-style-type: none"> • Do not touch the LED-PCBs! 	
	<p>Opening:</p> <ul style="list-style-type: none"> • Loosen the two mounting screws (TORX 6) of the enclosure cover (1). • Carefully swivel down the enclosure cover (2). <p>Proceed in reverse order to close:</p> <ul style="list-style-type: none"> • Carefully close the enclosure cover (2). • Tighten the enclosure cover with two mounting screws (TORX 6, tightening torque 5 Nm) (1).

7.3.2 Electrical connections

Electrical connection

Observe the maximum clamping possibility of the connection terminals (see chapter "Technical data").

Observe the following when connecting to the electrical connection:

- Clamping must be carried out precisely.
- Do not clamp any part of the conductor insulation.
- Do not mix up the conductors.
- Observe the technical regulations when connecting the conductor.
- Clamp the conductor firmly.

Connection terminals

Clamping range:

1 x 1.5 to 6 mm² (solid)

1 x 1.5 to 4 mm² (finely stranded)

1 x 1.5 to 6 mm² (finely stranded with core end sleeves)

(2 free clamping units per pole available)

Stripping length:

10 to 12 mm

Standard:

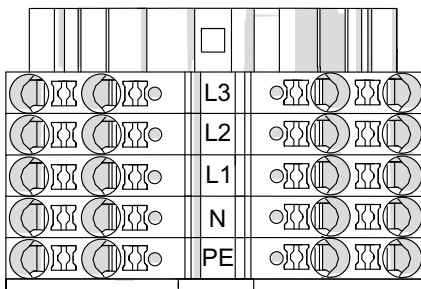

- L1, L2, L3 = phase
- N = neutral conductor
- PE = protective conductor

20219E00

with DALI connection:

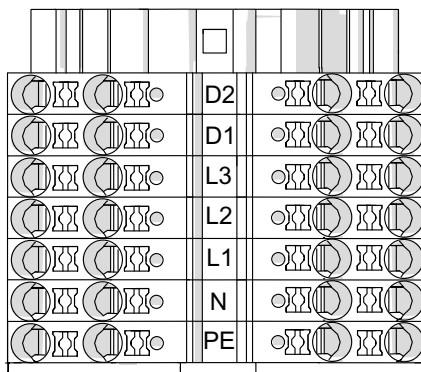

- D1, D2 = DALI connection
- L1, L2, L3 = phase
- N = neutral conductor
- PE = protective conductor

20221E00

Loop in/loop out wiring of the mains connection

DANGER	
	<p>Explosion hazard due to wrong electrical lines and/or cable entries and cable glands!</p> <p>Non-compliance results in severe or fatal injuries.</p> <ul style="list-style-type: none"> • Only use electrical lines, cable entries and cable glands which meet the special requirements for the service temperature.

For loop-out cable, don't use the port with gland Series 8161 (with red stopping plug). This is used for the restricted breathing test. Replace stopping plug Series 8290 with a certified gland and to be used for looping-out of the cables.

Special requirements for the service temperature of electrical lines, cable entries and cable glands for loop in/loop out wiring:

Version	Variant	at ambient temperature	$I_N \leq 10 \text{ A}$	$10 \text{ A} \leq I_N \leq 16 \text{ A}$	
			Electrical lines	Cable entry, cable gland	
6525/21..-17..-....-...	100 W	+50 to +60 °C	$\geq +75 \text{ °C}$	$\geq +90 \text{ °C}$	$\geq +80 \text{ °C}$
6525/21..-15..-....-...		+50 to +60 °C	$\geq +75 \text{ °C}$	$\geq +95 \text{ °C}$	$\geq +85 \text{ °C}$
6525/21..-16..-....-...		$\leq +50 \text{ °C}$	–	$\geq +85 \text{ °C}$	$\geq +75 \text{ °C}$
6525/21..-35..-....-...	160 W	+50 to +60 °C	$\geq +70 \text{ °C}$	$\geq +100 \text{ °C}$	$\geq +85 \text{ °C}$
6525/21..-36..-....-...		$\leq +50 \text{ °C}$	–	$\geq +90 \text{ °C}$	$\geq +80 \text{ °C}$
6525/21..-37..-....-...					
6525/21..-55..-....-...	225 W	+50 to +60 °C	$\geq +75 \text{ °C}$	$\geq +95 \text{ °C}$	$\geq +85 \text{ °C}$
6525/21..-56..-....-...		$\leq +50 \text{ °C}$	–	$\geq +85 \text{ °C}$	$\geq +80 \text{ °C}$
6525/21..-57..-....-...		$\leq +60 \text{ °C}$	$\geq +85 \text{ °C}^*$	$\geq +110 \text{ °C}$	$\geq +95 \text{ °C}$
6525/22..-15..-....-...	100 W	+50 to +60 °C	–	$\geq +95 \text{ °C}$	$\geq +85 \text{ °C}$
6525/22..-16..-....-...		$\leq +50 \text{ °C}$	–	$\geq +85 \text{ °C}$	$\geq +75 \text{ °C}$
6525/22..-35..-....-...	160 W	+50 to +60 °C	$\geq +70 \text{ °C}$	$\geq +100 \text{ °C}$	$\geq +85 \text{ °C}$
6525/22..-36..-....-...		$\leq +50 \text{ °C}$	–	$\geq +90 \text{ °C}$	$\geq +80 \text{ °C}$
6525/22..-55..-....-...	225 W	+50 to +60 °C	$\geq +75 \text{ °C}$	$\geq +95 \text{ °C}$	$\geq +85 \text{ °C}$
6525/22..-56..-....-...		$\leq +50 \text{ °C}$	–	$\geq +85 \text{ °C}$	$\geq +80 \text{ °C}$

* Cable entry, cable gland with permissible service temperature of $\geq 80 \text{ °C}$ is required.

	<p>Recommendation Use the following cable glands:</p> <ul style="list-style-type: none"> • 243464 – CMP-20A2F NB M20 screw connection • 107642 – CMP-25A2F NB M25 screw connection
---	--

7.3.3 Cable entries

Luminaires with cable entries, cable glands and stopping plugs which are not supplied by R. STAHL Schaltgeräte GmbH

	DANGER
	<p>Explosion hazard due to impermissible cable entries, cable glands and stopping plugs! Non-compliance results in severe or fatal injuries.</p> <ul style="list-style-type: none"> • Only use separately certified cable glands and stopping plugs which have been tested and certified according to Directive 2014/34/EU (ATEX) or IECEx (CoC) and which comply with the standard version stated in the certificate of the luminaire.



Please observe the following:

- the required dust resistance!
- the required type of protection!
- the required temperature resistance!
- the IP degree of protection according to the rating plate!
- the operating instructions of the cable entries and stopping plugs!
- the required tightening torques!
- the range of the permissible cable diameter!
- Insert the metal cable entries and/or stopping plugs into the PE!

	DANGER
	<p>Explosion hazard if breathers are used! Non-compliance results in severe or fatal injuries.</p> <ul style="list-style-type: none"> • Do not use breathers for series 6525/21 (nR version).

	<p>Cable glands and stopping plugs must be approved for the following types of protection:</p> <p>a) restricted breathing (nR) and dust (IIIC) for series 6525/21 (nR version) b) increased safety (e) and dust (IIIC)</p>
---	---



8 Commissioning

	<p style="text-align: center;">DANGER</p> <p>Explosion hazard due to incorrect installation! Non-compliance results in severe or fatal injuries.</p> <ul style="list-style-type: none"> • Check the device for proper installation before commissioning. • Comply with national regulations.
	<p style="text-align: center;">DANGER</p> <p>Explosion hazard due to incorrect installation! Non-compliance results in severe or fatal injuries.</p> <ul style="list-style-type: none"> • Carry out the restricted breathing test prior to first commissioning for series 6525/21 (nR version). (See chapter "Restricted breathing test")
<p style="text-align: center;">NOTICE</p> <p>Malfunction or device damage caused by condensation. Non-compliance can result in material damage!</p> <ul style="list-style-type: none"> • operate the luminaire continuously or periodically over extended periods of time. • avoid thermal bridges. 	

Before commissioning, ensure the following:

- Check the mounting and installation.
- Inspect enclosure for damage.
- If necessary, remove foreign bodies.
- If necessary, clean the connection chamber.
- Check if the conductors have been inserted correctly.
- Check if all screws and nuts have been tightened firmly.
- Check if all drilled holes are closed.
- Check whether all the cable entries and stopping plugs have been tightened firmly.
- Check if all conductors have been clamped firmly.
- Check if the line voltage and the rated operational voltage are consistent.
- Check if the permissible conductor diameter for the corresponding cable entries have been used.
- Check if the device is closed according to regulations.
- Check whether the bracket mounting & cover mounting screws are tightened with proper torque.

9 Maintenance, Overhaul, Repair

	DANGER
	<p>Explosion hazard due to hot built-in components! Non-compliance results in severe or fatal injuries.</p> <ul style="list-style-type: none"> • Only open the enclosure in switched-off state.
	CAUTION
	<p>Risk of electric shock or malfunction of the device due to unauthorized work! Non-compliance can result in light injuries!</p> <ul style="list-style-type: none"> • Before carrying out work on the device, switch off voltage supply. • Work performed on the device must only be carried out by authorized and appropriately trained qualified electricians.
NOTICE	
<p>Danger due to electrostatic discharge. Electronic components can be destroyed if touched.</p> <ul style="list-style-type: none"> • Do not touch the LED-PCBs! 	

9.1 Maintenance

- Consult the relevant national regulations to determine the type and extent of inspections.
- Adapt inspection intervals to the operating conditions.
- Perform maintenance and repair work in accordance with IEC 60079-17 and IEC 60079-19.

	Observe the relevant national regulations in the country of use.
---	--

As a minimum, check the following points during maintenance work on the device:

- Whether the clamping screws holding the cables are securely seated
- Whether the device enclosure and/or protective enclosure have cracks or other visible signs of damage
- Whether the seal shows signs of ageing or damage (completely replace enclosure components with damaged foamed seal)
- Whether the device is clean inside and out
- Whether the permissible temperatures (in accordance with EN 60079) are complied with
- Whether the cable entry is intact and securely tightened
- Whether the cables and lines show signs of ageing and damage
- Intended use and function.
- Restricted breathing of enclosure (see chapter "Restricted breathing test").

	If the restricted breathing test has failed, take the device out of operation!
---	--

NOTICE

Moisture on the inside of the luminaire can result in damage to electric and electronic components.

- Remove moisture with a cloth!
- Determine the source and eliminate the cause!
- Avoid condensation and thermal bridges!

	WARNING
	<p>Restricted breathing is not guaranteed any longer! Explosion protection is impaired!</p> <ul style="list-style-type: none"> • After replacing seals or enclosure components carry out the restricted breathing test acc. to IEC/EN 60079-15, para. 23.2.3.2.1.1.

9.1.1 Restricted breathing test (only variant 6525/21..)

The luminaire is equipped with a test device for restricted breathing.

Restricted breathing must be checked after installation and during regular maintenance acc. to IEC/EN 60079-15.

Inspection according to IEC/EN 60079-15, para. 23.2.3.2.1.1

	<p>Recommendation Check the luminaire by using the handheld testing instrument for restricted breathing from R. STAHL Schaltgeräte GmbH (see data sheet).</p>
---	--

	The test should only be carried out at constant temperature conditions.
---	---

	If the luminaire is only marked with the type of protection for dust (IIIC), the cable entries and stopping plugs do not need to meet the requirements for restricted breathing (nR).
---	---

Preparing the luminaires for testing:

- Remove the red stopping plug.

Test:

- Insert the hose of the test device into the cable entry for testing restricted breathing.
- Hand-tighten the cable entry.
- Use the hand pump to create a vacuum of 0.3 kPa (3 mbar).

The test has been passed if after 90 seconds a vacuum of at least 0.15 kPa (1.5 mbar) is still present in the luminaire.

After the test:

- Remove the hose of the test device for testing restricted breathing from the cable entry.
- Close the luminaire using the red stopping plug.

Alternative pressure and time specifications:

	Alternative 1	Alternative 2
Vacuum at start of test	3.0 kPa (30 mbar)	0.3 kPa (3 mbar)
Test duration	14 seconds	14 seconds
Vacuum after testing	2.7 kPa (27 mbar)	0.27 kPa (2.7 mbar)

9.2 Repair

	DANGER
	<p>Explosion hazard due to improper repair! Non-compliance results in severe or fatal injuries.</p> <ul style="list-style-type: none"> • Repair work on the devices must be performed only by R. STAHL Schaltgeräte GmbH.

9.3 Returning the device

- Only return or package the devices after consulting R. STAHL!
Contact the responsible representative from R. STAHL.

R. STAHL's customer service is available to handle returns if repair or service is required.

- Contact customer service personally.

or

- Go to the r-stahl.com website.
- Under "Support" > "RMA" > select "RMA-REQUEST".
- Fill out the form and send it.
You will automatically receive an RMA form via email. Please print this file off.
- Send the device along with the RMA form in the packaging to
R. STAHL Schaltgeräte GmbH (refer to chapter 1.1 for the address).

10 Cleaning

	DANGER
	<p>Explosion hazard due to heavy deposits of combustible dusts! Non-compliance results in severe or fatal injuries.</p> <ul style="list-style-type: none"> • Deposits of combustible dusts through regular cleaning according to EN/IEC 60079-14.

- To avoid electrostatic charging, the devices located in potentially explosive areas may only be cleaned using a damp cloth.
- When cleaning with a damp cloth, use water or mild, non-abrasive, non-scratching cleaning agents.
- Do not use aggressive detergents or solvents.

11 Disposal

- Observe national and local regulations and statutory regulation regarding disposal.
- Separate materials when sending it for recycling.
- Ensure environmentally friendly disposal of all components according to the statutory regulations.

12 Accessories and Spare parts

NOTICE

Malfunction or damage to the device due to the use of non-original components.
Non-compliance can result in material damage.

- Use only original accessories and spare parts from R. STAHL Schaltgeräte GmbH.



For accessories and spare parts, see data sheet on our homepage
r-stahl.com.

EU-Konformitätserklärung
EU Declaration of Conformity
Déclaration de Conformité UE



R. STAHL Schaltgeräte GmbH • Am Bahnhof 30 • 74638 Waldenburg, Germany
 erklärt in alleiniger Verantwortung, *declares in its sole responsibility, déclare sous sa seule responsabilité,*

dass das Produkt: LED Scheinwerfer
that the product: LED Floodlight
que le produit: LED Projecteur

Typ(en), type(s), type(s): 6525/2

mit den Anforderungen der folgenden Richtlinien und Normen übereinstimmt.
is in conformity with the requirements of the following directives and standards.
est conforme aux exigences des directives et des normes suivantes.

Richtlinie(n) / Directive(s) / Directive(s)		Norm(en) / Standard(s) / Norme(s)
2014/34/EU 2014/34/EU 2014/34/UE	ATEX-Richtlinie ATEX Directive Directive ATEX	EN IEC 60079-0:2018 EN 60079-1:2014 EN IEC 60079-7:2015 + A1:2018 EN IEC 60079-15:2019 EN 60079-28:2015 EN 60079-31:2014
Kennzeichnung, marking, marquage:		II 3 G Ex nR IIC T6...T4 Gc (6525/21..) II 3 G Ex db ec IIC T4 Gc (6525/22..) II 2 D Ex tb op is IIIC T80°C...T100°C Db 
EU-Baumusterprüfbescheinigung: <i>EU-Type Examination Certificate:</i> <i>Attestation d'examen UE de type:</i>		EPS 15 ATEX 1 991 (Bureau Veritas Consumer Products Services Germany GmbH, Businesspark A96, 86842 Tuerkheim, Germany)
Produktnormen nach Niederspannungsrichtlinie: <i>Product standards according to Low Voltage Directive:</i> <i>Normes des produit pour la Directive Basse Tension:</i>		EN 60598-1:2015 + A1:2018 EN 62471:2008
2014/30/EU 2014/30/EU 2014/30/UE	EMV-Richtlinie EMC Directive Directive CEM	EN 55015:2013 + A1:2015 EN 61547:2009 EN 61000-3-2:2014 EN 61000-3-3:2013
2011/65/EU 2011/65/EU 2011/65/UE	RoHS-Richtlinie RoHS Directive Directive RoHS	EN IEC 63000:2018

Waldenburg, 2020-10-27
 Ort und Datum
Place and date
Lieu et date

i.V. 
 Dr. A. Kaufmann
 Senior Vice President Marketing & Innovation
 Vice-Président directeur Marketing & Innovation

i.V. 
 J. Freimüller
 Vice President global Quality Management
 Vice-Président globale Gestion de Qualité