

1279 Duragauge[®] Pressure Gauge

FEATURES

- Custom dial printing options
- Micrometer adjustable pointer
- **PLUS!**[™] Performance option dampens vibration, shock and pulsation effects
- Pressure range from Vacuum to 2000 bar/30,000 psi

TYPICAL USES

- Refineries
- Chemical and petrochemical plants
- Offshore oil rigs
- Water and wastewater pressure control
- Pulp and water
- Mining and metals
- Equipment skids
- Specialized OEM equipment
- Cryogenics



1279
4 1/2" dial size



SPECIFICATIONS

Accuracy:	±0,5 % of span (ASME B40.100 Grade 2A)
Dial Size:	4 1/2" (115 mm)
Range:	Vacuum, Compound to 2000 bar/30,000 psi
Process Connection Location:	Lower, back, side, top
Process Connection:	1/4 NPT Male, 1/2 NPT Male, G 1/2 B Male, M20x1,5 Male, 9/16 -18 UNF-2B (high pressure connection)
Case Style:	Solid front with pressure relief back
Window:	Glass (STD.), acrylic, shatter proof glass, non-glare glass (OPT.)
Movement:	Rotary, adjustable
Movement Materials:	Stainless steel 400, Teflon [®] coated pinion gear and segment
Dial:	Aluminum, white background, black scale
Pointer:	Micrometer, adjustable, aluminum
Weather Protection:	Dry case: Case not sealed, recommended for weather protected environment only Liquid filled or field fillable: IP66 or NEMA 4X (S&P tube and socket) NEMA 4 (A&R tube and socket) Hermetically sealed: IP66
Dampening Options:	Liquid: glycerin, silicone, Halocarbon [®] , PLUS! [™] Performance
Mounting:	Stem, surface (STD.), flush, pipe, remote (OPT.)
Approvals:	CRN, CE (PED), EAC

WETTED COMPONENTS

Bourdon Tube	Process Connection Materials	Joints
1.4404 / 316L St.st.	1.4404 / 316L St.st.	Welded
1.4404 / 316L St.st.	Steel	Welded
K-Monel [®] 500	Monel [®] 400	Welded
C510 Phos. Bronze	Brass	Silver brazed

KEY BENEFITS

- Available with a wide variety of accessory and diaphragm seal assemblies
- Available with high process temperature dissipation siphons

NON-WETTED COMPONENTS

Case	Ring	Pressure Relief Back
Phenolic	Threaded, Polycarbonate (Meets UL 94 V-0)	Polycarbonate (Meets UL 94 V-0)

MIN./MAX. TEMPERATURE LIMITS

VERSION	AMBIENT	PROCESS	STORAGE
Dry	-29 °C to 93 °C (-20 °F to 200 °F)	-29 °C to 121 °C (-20 °F to 250 °F)	-40 °C to 121 °C (-40 °F to 250 °F)
PLUS! [™]	-40 °C to 66 °C (-40 °F to 150 °F)	-40 °C to 93 °C (-40 °F to 200 °F)	-40 °C to 66 °C (-40 °F to 150 °F)
Glycerine	-7 °C to 66 °C (20 °F to 150 °F)	-7 °C to 66 °C (20 °F to 150 °F)	-18 °C to 66 °C (0 °F to 150 °F)
Silicone	-40 °C to 66 °C (-40 °F to 150 °F)	-40 °C to 93 °C (-40 °F to 200 °F)	-40 °C to 66 °C (-40 °F to 150 °F)
Halocarbon [®]	-40 °C to 66 °C (-40 °F to 150 °F)	-40 °C to 93 °C (-40 °F to 200 °F)	-40 °C to 66 °C (-40 °F to 150 °F)

Note: Other than discoloration of the dial and hardening of the gasketing that may occur as ambient or process temperatures exceeds 150 °F, non-liquid-filled gauges with standard glass windows, can withstand continuous operating temperatures up to 121 °C (250 °F). Liquid-filled gauges can withstand 93 °C (200 °F) but glycerin fill and acrylic window will tend to yellow. Accuracy at temperatures above or below the reference ambient temperature of 20 °C (68 °F) will be affected by approximately 0,3% per 10 K.

Gauges with welded joints will withstand 400 °C (750 °F), 232°C (450 °F) with silver brazed joints for short times without rupture, although other parts of the gauge will be destroyed and calibration will be lost.

For continuous use and for process or ambient temperatures above 121 °C (250 °F), a diaphragm seal or capillary or siphon is recommended.

1279 Duragauge[®] Pressure Gauge

ORDERING CODE		EXAMPLE:	45	1279	S	SH	04	L	1BR	XLL
Dial Size										
45	4 1/2" (115 mm)		45							
Model Code										
1279	Solid front process gauge			1279						
System (tube and process connection)										
A	Bronze tube, brass process connection, Max. pressure 70 bar/1,000 psi									
P	K-Monel [®] 500 tube, Monel [®] 400 process connection, Max. pressure 2000 bar/30,000 psi									
R	1.4404/316L St.st. tube, steel process connection, Max. pressure 1400 bar/20,000 psi									
S	1.4404/316L St.st. tube and process connection, Max. pressure 1400 bar/20,000 psi				S					
Case Design										
S	Solid front case, dry									
SH	Solid front case, dry, hermetically sealed					SH				
SL	Solid front case, liquid filled (glycerin STD.)									
Process Connection Sizes										
02	1/4 NPT Male (N/A for ranges over 1400 bar/20,000 psi)									
04	1/2 NPT Male (N/A for ranges over 1400 bar/20,000 psi)						04			
09	9/16-18 UNF-2B (high pressure fitting, standard for pressures over 1400 bar/20,000 psi)									
15	G 1/2 B Male (system S only, N/A for ranges over 1000 bar/15,000 psi)									
16	M20x1,5 Male (system S only, N/A for ranges over 1000 bar/15,000 psi)									
AM	AND 10050-4 (1/4 tubing connection)									
RW	SAE 7/16-20 Straight thread									
Process Connection Location										
L	Lower							L		
B	Back									
D	Side connection (3 o'clock)									
E	Side connection (9 o'clock)									
T	Top connection									
Range (coding examples only, see range table on page 4 for all standard ranges)										
Single Scales										
15#	15 psi									
1BR	1 bar								1BR	
1KG	1 kg/cm ²									
100KP	100 kPa									
Dual Scales										
15#/BR	15 psi inner scale / 1 bar outer scale									
1BR/#	1 bar inner scale / 15 psi outer scale									
Options (If choosing an option(s) must include a "X")										X__
Dampening										
LL	PLUS! [™] Performance									LL
NZ	PLUS! [™] Performance silicone free									
GV	Silicone case fill									
GX	Halocarbon [®] case fill									
TS	Throttle screw (Standard with liquid filled, hermetically sealed or PLUS! [™] Performance)									
Case/Ring/Dial										
56	Black flush mounting ring type 1278M									
57	Polished stainless steel flush mounting ring type 1278MC									
D3	DuraVis [™] Retroreflective Dial (dry case only)									

continued at page 3



1279 Duragauge[®] Pressure Gauge

STANDARD PRESSURE RANGES					
	psi	bar	kPa	MPa	kg/cm ²
Vacuum	30IMV	N1BR	N100KP	N1MP	N1KG
	-	N1/0.6BR	N100/60KP	0.1/0.06MP	N1/0.6KG
Compound	V/15#	-	-	-	-
	-	N1/1.5BR	N100/150KP	N0.1/0.15MP	N1/1.5KG
	V/30#	-	-	-	-
	-	N1/3BR	N100/300KP	N0.1/0.3MP	N1/3KG
	V/60#	-	-	-	-
	-	N1/5BR	N100/500KP	N0.1/0.5MP	N1/5KG
	V/100#	-	-	-	-
	-	N1/9BR	N100/900KP	N0.1/0.9MP	N1/9KG
	15#	1BR	100KP	0.1MP	1KG
	20#	-	-	-	-
Positive Pressure	-	1.6BR	160KP	0.16MP	1.6KG
	30#	-	-	-	-
	-	2.5BR	250KP	0.25MP	2.5KG
	60#	4BR	400KP	0.4MP	4KG
	-	6BR	600KP	0.6MP	6KG
	100#	-	-	-	-
	120#	-	-	-	-
	-	10BR	1000KP	1MP	10KG
	160#	-	-	-	-
	200#	-	-	-	-
	-	16BR	1600KP	1.6MP	16KG
	300#	-	-	-	-
	-	25BR	2500KP	2.5MP	25KG
	400#	-	-	-	-
	500#	-	-	-	-
	600#	40BR	4000KP	4MP	40KG
	800#	-	-	-	-
	-	60BR	6000KP	6MP	60KG
	1000#	-	-	-	-
	1500#	100BR	10000KP	10MP	100KG
	2000#	-	-	-	-
	-	160BR	16000KP	16MP	160KG
	3000#	-	-	-	-
	-	250BR	25000KP	25MP	250KG
	4000#	-	-	-	-
	5000#	-	-	-	-
	6000#	400BR	40000KP	40MP	400KG
	8000#	-	-	-	-
-	600BR	60000KP	60MP	600KG	
10000#	-	-	-	-	
15000#	1000BR	100000KP	100MP	1000KG	
20000#	-	-	-	-	
-	1600BR	-	160MP	1600KG	
30000#	-	-	-	-	



1279 Duragauge® Pressure Gauge

DIMENSIONS IN MM [INCH]

For reference only, consult Ashcroft for specific dimensional drawings

DIAL SIZE INCHES	A	B	C	D	E	F	G	H	J	K	T	V	WEIGHT (KG)
4 1/2	147,6 [5,81]	85,3 [3,36]	128,7 [5,07]	40,6 [1,60]	137 [5,375]	41,2 [1,62]	99,6 [3,92]	18,4 [0,73]	5,5 [0,22]	66,7 [2,62]	23,9 [0,94]	67 [2,625]	1,1 (Dry) 1,6 (L.F.)

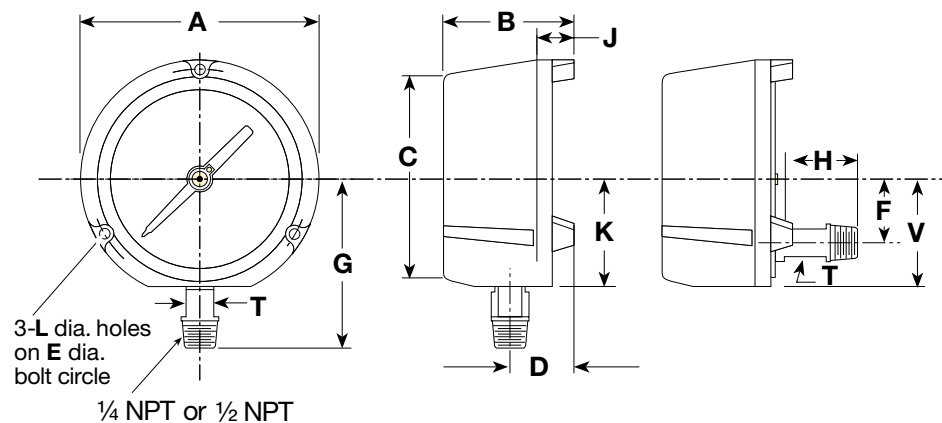

1278M SERIES FLUSH MOUNTING RING

1278M Series Flush Mounting Ring. Used to flush mount gauge case 1279(*)S. Black finish (STD.); Polished SS finish (OPT.)

GAUGE SIZE INCHES	RING O.D.	"A" DIA.	"B" SIZE OF 3 SCREWS	"C" SIZE OF WASHERS
4 1/2	152 [6]	148 [5.625]	#10-24 x 1 1/8	7/16 x 1 1/64 x 5/8

